



厦门炬垒森科技有限公司

Xiamen Toroson Technology Co., Ltd

TFT-LCD Module

SPECIFICATION

Customer: _____

Model Name: VL097IA14

SPEC NO.: _____

Date: _____

Version: _____

Preliminary Specification

Final Specification

For Customer's Acceptance

Approved by	Comment

Approved by	Reviewed by	Prepared by



Record of Revision

Toroson Group copyright 2019
All right reserved, Copying forbidden.

Version	Revise Date	Page	Content



Contents

1.General Specifications.....	01
2.Pin Assignment.....	02
3.Operation Specifications.....	04
3.1.Absolute Maximum Ratings.....	04
3.2.Typical Operation Conditions.....	05
3.3.Current Consumption.....	05
3.3.1.Current for LCD Driver.....	05
3.3.2.Current for LED Driver.....	05
3.4.Power Sequence.....	06
3.5.Timing Characteristics.....	07
3.5.1. DC Electrical Characteristics.....	07
3.5.2. Timing Table.....	07
3.5.3.LVDS Data Input Format.....	08
4.Optical Specifications.....	09
5.Reliability Test Items.....	13
6.General Precautions.....	14
6.1.Safety.....	14
6.2.Handling.....	14
6.3.Static Electricity.....	14
6.4.Storage.....	14
6.5.Cleaning.....	14
7.Mechanical Drawing.....	15
8.Package Drawing.....	16

1. General Specifications

No.	Item	Specification	Remark
1	LCD size	9.7 inch	
2	Driver element	a-Si TFT active matrix	
3	Resolution	1024X3(RGB)X768	
4	Display mode	Normally Black, Transmissive	
5	Dot pitch	0.192(W)x0.192(H) mm	
6	Active area	196.608(W)x147.456(H) mm	
7	Module size	210.16(W)x164.25(H)x2.85(D)mm	Note 1
8	View direction(Gray inversion)	Free	
9	Surface treatment	Plain	
10	Color arrangement	RGB-stripe	
11	Interface	LVDS	
12	Backlight power consumption	2.232W (Typ.)	
13	Panel power consumption	TBD	
14	Weight	TBD	

Note 1: Refer to Mechanical Drawing.

2.Pin Assignment

A 30pin connector is used for the module electronics interface.

Pin No.	Symbol	Description
1	VSS	Ground
2	VCC	Power Supply(3.3V typ.)
3	VCC	Power Supply(3.3V typ.)
4	VEDID	DDC 3.3V power
5	GSP	GSP(Reserved)
6	CLKEDID	DDC clock
7	DATAEDID	DDC data
8	Rxin0-	Negative LVDS differential data input
9	Rxin0+	Positive LVDS differential data input
10	VSS	Ground
11	Rxin1-	Negative LVDS differential data input
12	Rxin1+	Positive LVDS differential data input
13	VSS	Ground
14	Rxin2-	Negative LVDS differential data input
15	Rxin2+	Positive LVDS differential data input
16	VSS	Ground
17	RxCLK-	Negative LVDS differential data input
18	RxCLK+	Positive LVDS differential data input
19	VSS	Ground
20	NC	No Connection(Reserved)
21	Vdc	LED Anode
22	Vdc	LED Anode
23	NC	No Connection(Reserved)
24	Vdc1	LED Cathode1
25	Vdc2	LED Cathode2
26	Vdc3	LED Cathode3



27	Vdc4	LED Cathode4
28	Vdc5	LED Cathode5
29	Vdc6	LED Cathode6
30	NC	No Connection(Reserved)

3. Operation Specifications

3.1. Absolute Maximum Ratings

(Note 1)

Item	Symbol	Values		Unit	Remark
		Min.	Max.		
Power voltage	VCC	-0.3	5.0	V	VSS=0V TA=25°C
LED Reverse Voltage	VR	-	30	V	
Peak Forward Current	I _{fp}	-	180	V	
Power Dissipation	P _d	-	2376	mW	
Operating temperature	T _{OP}	-10	50	.	
Storage temperature	T _{ST}	-20	60	°C	

Note 1: The absolute maximum rating values of this product are not allowed to be exceeded at any times. Should a module be used with any of the absolute maximum ratings exceeded, the characteristics of the module may not be recovered, or in an extreme case, the module may be permanently destroyed.

3.2. Typical Operation Conditions

Test condition: GND=0V, TA=25 °C (Note 1)

Item	Symbol	Values			Unit	Remark
		Min.	Typ.	Max.		
Power voltage	V _{CC}	3.0	3.3	3.6	V	Note 1
Input logic high voltage	V _{IH}	0.8V _{CC}	-	V _{CC}	V	
Input logic low voltage	V _{IL}	0	-	0.2V _{CC}	V	

Note 1: V_{CC} setting should match the signals output voltage of customer's system board.

3.3. Current Consumption

3.3.1. Current for LCD Driver

Item	Symbol	Values			Unit	Remark
		Min.	Typ.	Max.		
Current for Driver	I _{VCC}	-	100	120	mA	V _{CC} =3.3V

3.3.2. Current for LED Driver

Item	Symbol	Values			Unit	Remark
		Min.	Typ.	Max.		
Voltage for LED Backlight	V _{LED}	17	18	20	V	Note 1
Current for LED Backlight	I _{LED}	110	120	130	mA	
LED life time	-	20000	-	-	Hr	Note 2

Note 1: The LED Supply Voltage is defined by the number of LED at Ta=25°C and I_{LED}=120mA

Note 2: The "LED life time" is defined as the module brightness decrease to 50% original brightness at Ta=25°C and I_{LED}=120mA. The LED lifetime could be decreased if operating IL is larger than 120mA.

3.4. Power Sequence

Power on\off:

The Power sequence specifications are shown as the following table and diagram.

Symbol	Value			Unit	Note
	Min.	Typ.	Max.		
T1	0.5	-	10	ms	
T2	0	20	50	ms	
T3	200	250	-	ms	
T4	200	250	-	ms	
T5	0.5	20	50	ms	
T6	0	-	20	ms	
T7	500	-	-	ms	

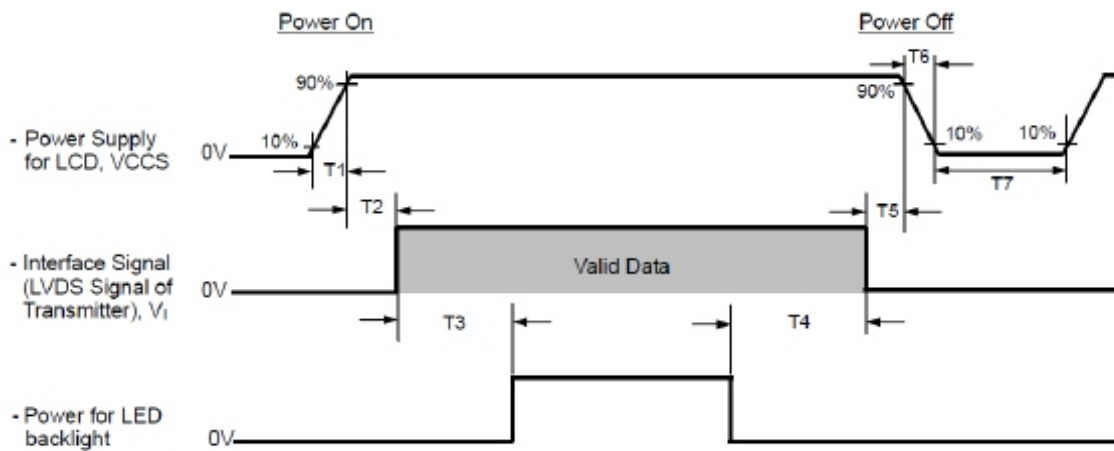

Note (1) Please don't plug or unplug the interface cable when system is turned on.

Note (2) Please avoid floating state of the interface signal during signal invalid period.

Note (3) It is recommended that the backlight power must be turned on after the power supply for LCD and the interface signal is valid.

3.5. Timing Characteristics

3.5.1. DC Electrical Characteristics

Parameter	Symbol	Values			Unit	Note
		Min.	Typ.	Max.		
LVDS Different Input High Threshold	$V_{TH(LVDS)}$	-	-	+100	mV	(1) $V_{CM}=1.2V$
LVDS Different Input Low Threshold	$V_{TH(LVDS)}$	-100	-	-	mV	(1) $V_{CM}=1.2V$
LVDS Common Mode Voltage	V_{CM}	1.125	1.200	1.375	V	(1)
LVDS Different Input Voltage	$ V_{ID} $	200	-	600	mV	(1)
LVDS Terminating Resistor	R_T	90	100	110	Ohm	-

Note(1):The parameters of LVDS signals are defined as the following figures.

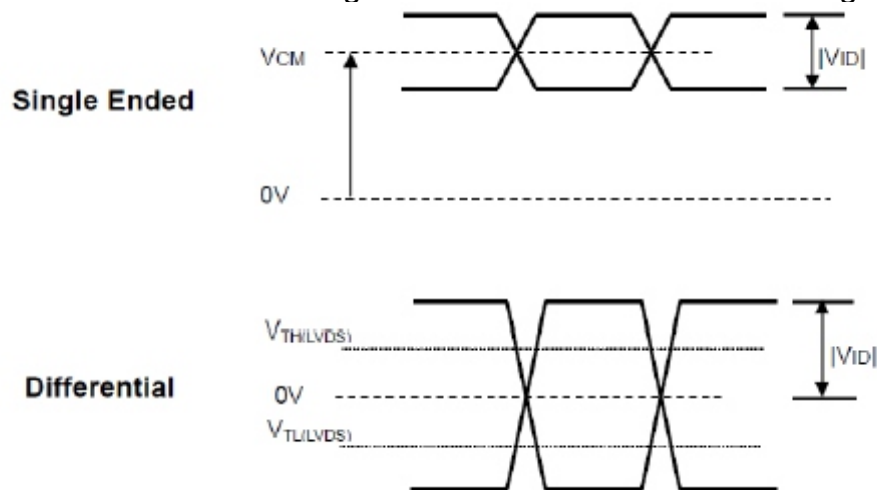

3.5.2. Timing Table

The input signal timing specification shown as the following table and timing diagram

Signal	Item	Symbol	Min.	Typ.	Max.	Unit	Note
DCLK	Frequency	$1/T_c$	52	65	71	MHZ	-
DE	Vertical Total Time	T_V	778	806	845	TH	-
	Vertical Active Display Period	T_{VD}	-	768	-	TH	-
	Vertical Active Blanking Period	T_{VB}	-	32	-	TH	-
	Horizontal Total Time	T_H	-	2084	-	T_c	-
	Horizontal Active Display Period	T_{HD}	-	1024	-	T_c	-
	Horizontal Active Blanking Period	T_{HB}	10	38	77	H	-

Note(1):Because this module is operated DE only mode.Hsync and Vsync are ignored.

INPUT SIGNAL TIMING DIAGRAM

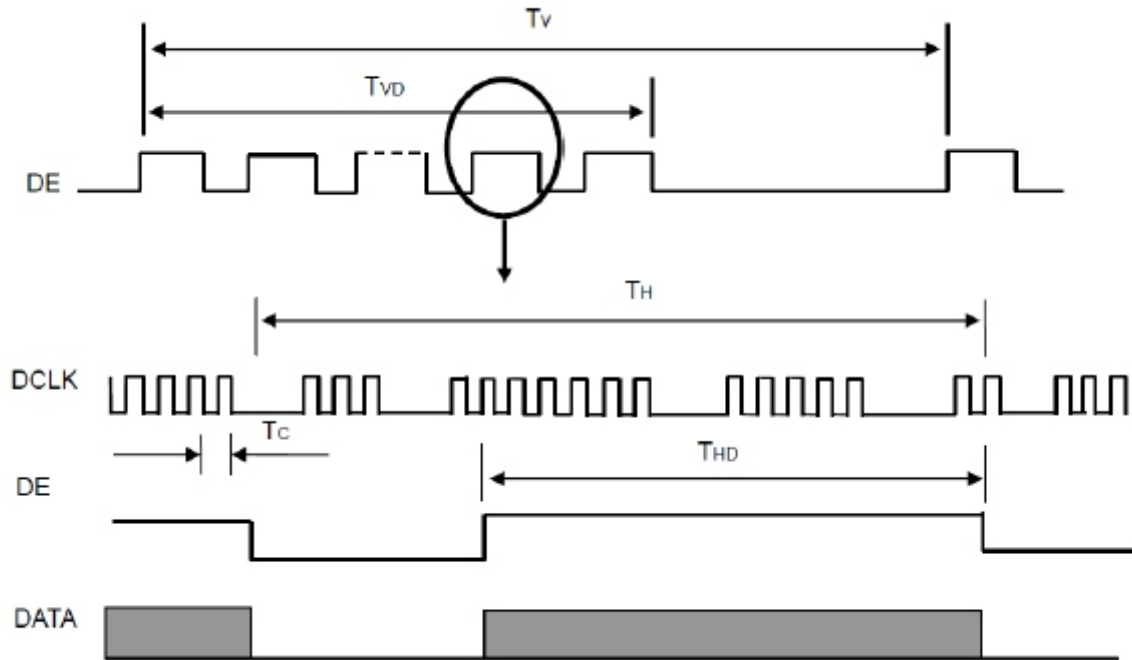

3.5.3. LVDS Data Input Format

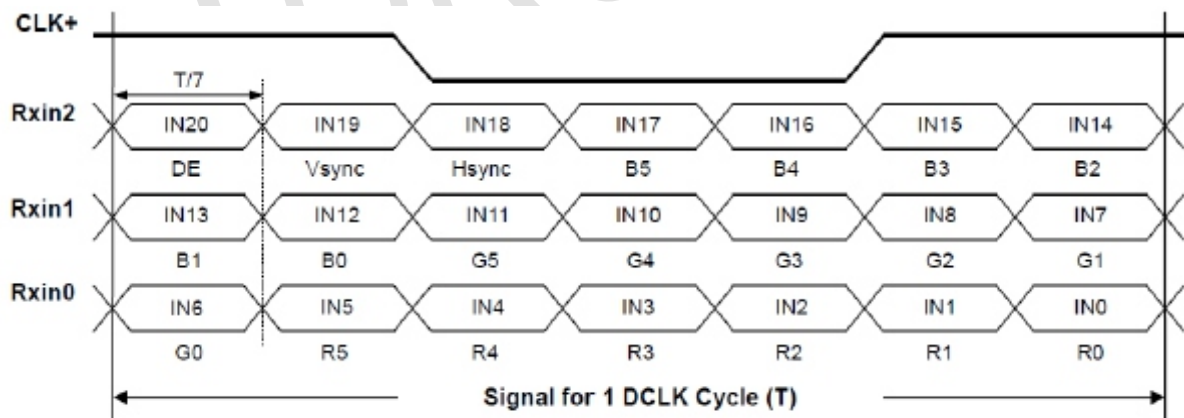

4. Optical Specifications

Item	Symbol	Condition	Values			Unit	Remark
			Min.	Typ.	Max.		
Viewing angle (Cr≥ 10)	θ_L	$\Phi=180^\circ$ (9 o'clock)	-	85	-	degree	Note 1
	θ_R	$\Phi=0^\circ$ (3 o'clock)	-	85	-		
	θ_T	$\Phi=90^\circ$ (12 o'clock)	-	85	-		
	θ_B	$\Phi=270^\circ$ (6 o'clock)	-	85	-		
Response time	T_{ON}	Normal $\theta=\Phi=0^\circ$	-	10	20	msec	Note 3
	T_{OFF}		-	15	30	msec	Note 3
Contrast ratio	C_R		600	800	-	-	Note 4
Color chromaticity	W_X		0.26	0.31	0.36	-	Note 2
	W_Y		0.28	0.33	0.38	-	Note 5 Note 6
Luminance	L		400	450	-	cd/m ²	Note 6
Luminance uniformity	Y_U		75	80	-	%	Note 7
Color Gamut	NTSC		50		%		

Test Conditions:

- $V_{LED}=18V$, $I_L=120mA$ (Backlight circuit: 6 series connection, 6 parallel connection), the ambient temperature is 25°C
- The test system refer to Note2.

Note 1: Definition of viewing angle range

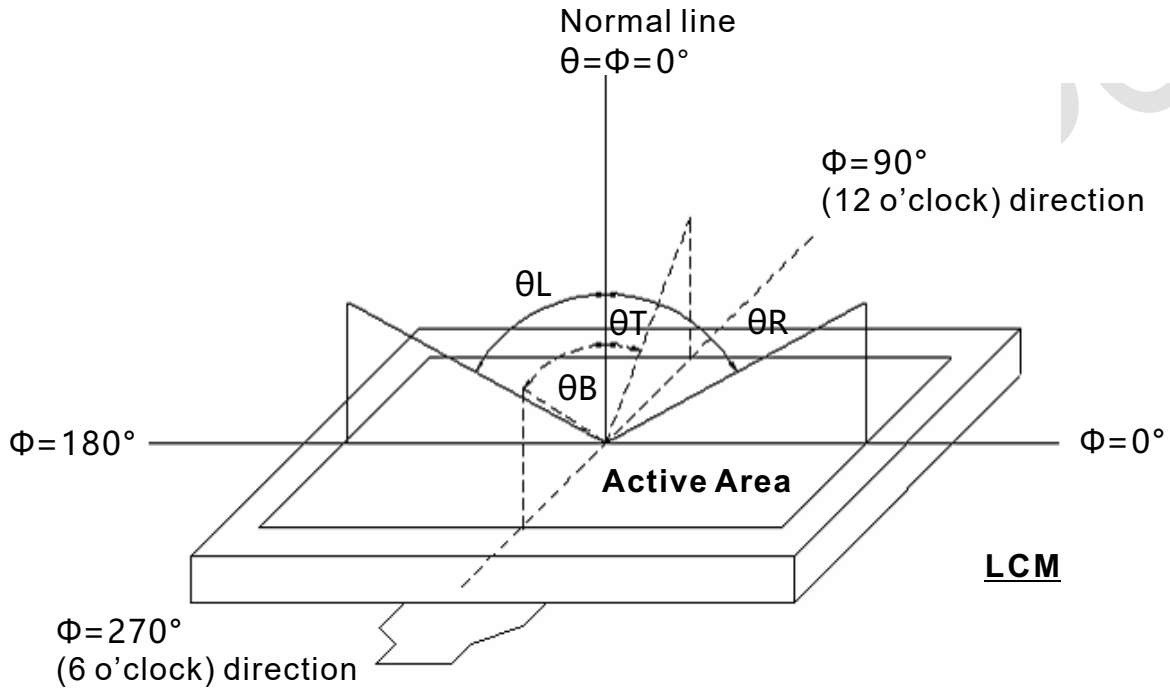

Fig. 4-1 Definition of viewing angle

Note 2: Definition of optical measurement system

The optical characteristics should be measured in dark room. After 30 minutes operation, the optical properties are measured at the center point of the LCD screen. (Response time is measured by Photo detector TOPCON BM-7, other items are measured by BM-5A/Field of view: 1°/Height: 500mm.)

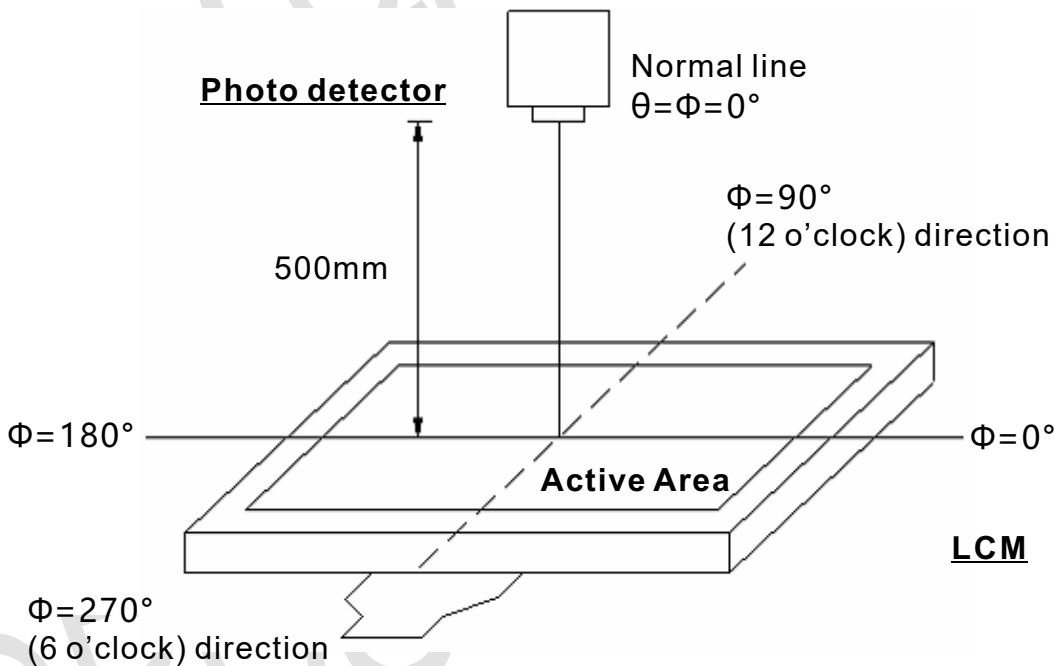

Fig. 4-2 Optical measurement system setup

The copyright belongs to Viete. Any unauthorized use is prohibited.

The copyright belongs to Toroson. Any unauthorized use is prohibited.

Note 3: Definition of Response time

The response time is defined as the LCD optical switching time interval between "White" state and "Black" state. Rise time (Ton) is the time between photo detector output intensity changed from 90% to 10%. And fall time (toff) is the time between photo detector output intensity changed from 10% to 90%.

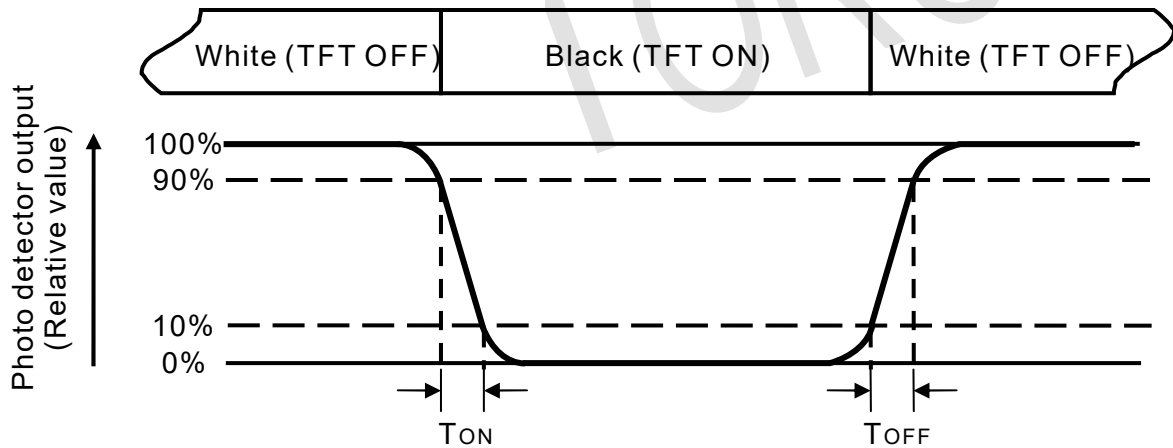

Fig. 4-3 Definition of response time

Note 4: Definition of contrast ratio

$$\text{Contrast ratio (CR)} = \frac{\text{Luminance measured when LCD on the "White" state}}{\text{Luminance measured when LCD on the "Black" state}}$$

Note 5: Definition of color chromaticity (CIE1931)

Color coordinates measured at center point of LCD.

Note 6: All input terminals LCD panel must be ground while measuring the center area of the panel. The LED driving condition is IL=120mA.

Note 7: Definition of Luminance Uniformity

Active area is divided into 9 measuring areas (Refer to Fig. 4-4). Every measuring point is placed at the center of each measuring area.

$$\text{Luminance Uniformity}(Y_u) = \frac{B_{\min}}{B_{\max}}$$

L-----Active area length W----- Active area width

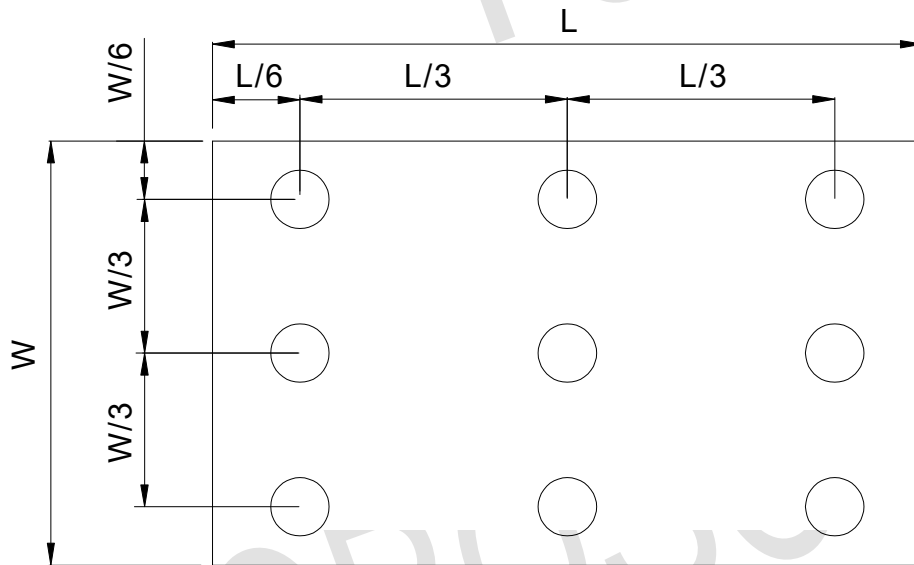

Fig. 4-4 Definition of measuring points

B_{max}: The measured maximum luminance of all measurement position.

B_{min}: The measured minimum luminance of all measurement position.

5. Reliability Test Items

(Note3)

Item	Test Conditions	Remark
High Temperature Storage	Ta = 60°C 120hrs	A,B,C,D,E
Low Temperature Storage	Ta = -20°C 120hrs	A,B,C,D,E
High Temperature Operation	Ta = 50°C 120hrs	A,B,C,D,E
Low Temperature Operation	Ta = -10°C 120hrs	A,B,C,D,E
Operate at High Temperature and Humidity	+40°C,90%RH 120hrs	A,B,C,D,E
Thermal Shock	-20°C/30 min~ +60°C/30 min for a total 100 cycles, Start with cold temperature and end with high temperature.	A,B,C,D,E
Vibration Test	Sweep:10Hz~55Hz~10Hz 2 hours for each direction of X. Y. Z. (6 hours for total)	A,B,C,D,E
Package Vibration Test	Random Vibration: 0.015G*G/Hz from 5-200HZ, -6dB/Octave from 200-500HZ 2 hours for each direction of X. Y. Z. (6 hours for total)	A,B,C,D,E
Package Drop Test	Height:60 cm 1 corner, 3 edges, 6 surfaces	A,B,C,D,E
Electro Static Discharge	±2KV, Human Body Mode, 100pF/1500Ω	A,B,C,D,E

※Criterion:

A.LCM each function is OK.

B.LCM appearance inspection without abnormalities (Including scratch, damage, corrosion and serious deformation).

C.LCM brightness above the Min. value of Spec.

D.Luminance uniformity above the Min. value of Spec.

E.Color chromaticity within tolerance range.

6. General Precautions

6.1. Safety

Liquid crystal is poisonous. Do not put it in your mouth. If liquid crystal touches your skin or clothes, wash it off immediately by using soap and water.

6.2. Handling

1. The LCD panel is plate glass. Do not subject the panel to mechanical shock or to excessive force on its surface.
2. The polarizer attached to the display is easily damaged. Please handle it carefully to avoid scratch or other damages.
3. To avoid contamination on the display surface, do not touch the module surface with bare hands.
4. Keep a space so that the LCD panels do not touch other components.
5. Put cover board such as acrylic board on the surface of LCD panel to protect panel from damages.
6. Transparent electrodes may be disconnected if you use the LCD panel under environmental conditions where the condensation of dew occurs.
7. Do not leave module in direct sunlight to avoid malfunction of the Ics.

6.3. Static Electricity

1. Be sure to ground module before turning on power or operating module.
2. Do not apply voltage which exceeds the absolute maximum rating value.

6.4. Storage

1. Store the module in a dark room where must keep at $25 \pm 10^{\circ}\text{C}$ and 65%RH or less.
2. Do not store the module in surroundings containing organic solvent or corrosive gas
3. Store the module in an anti-electrostatic container or bag.

6.5. Cleaning

1. Do not wipe the polarizer with dry cloth. It might cause scratch.
2. Only use a soft sloth with IPA to wipe the polarizer, other chemicals might permanent damage to the polarizer.

7. Mechanical Drawing

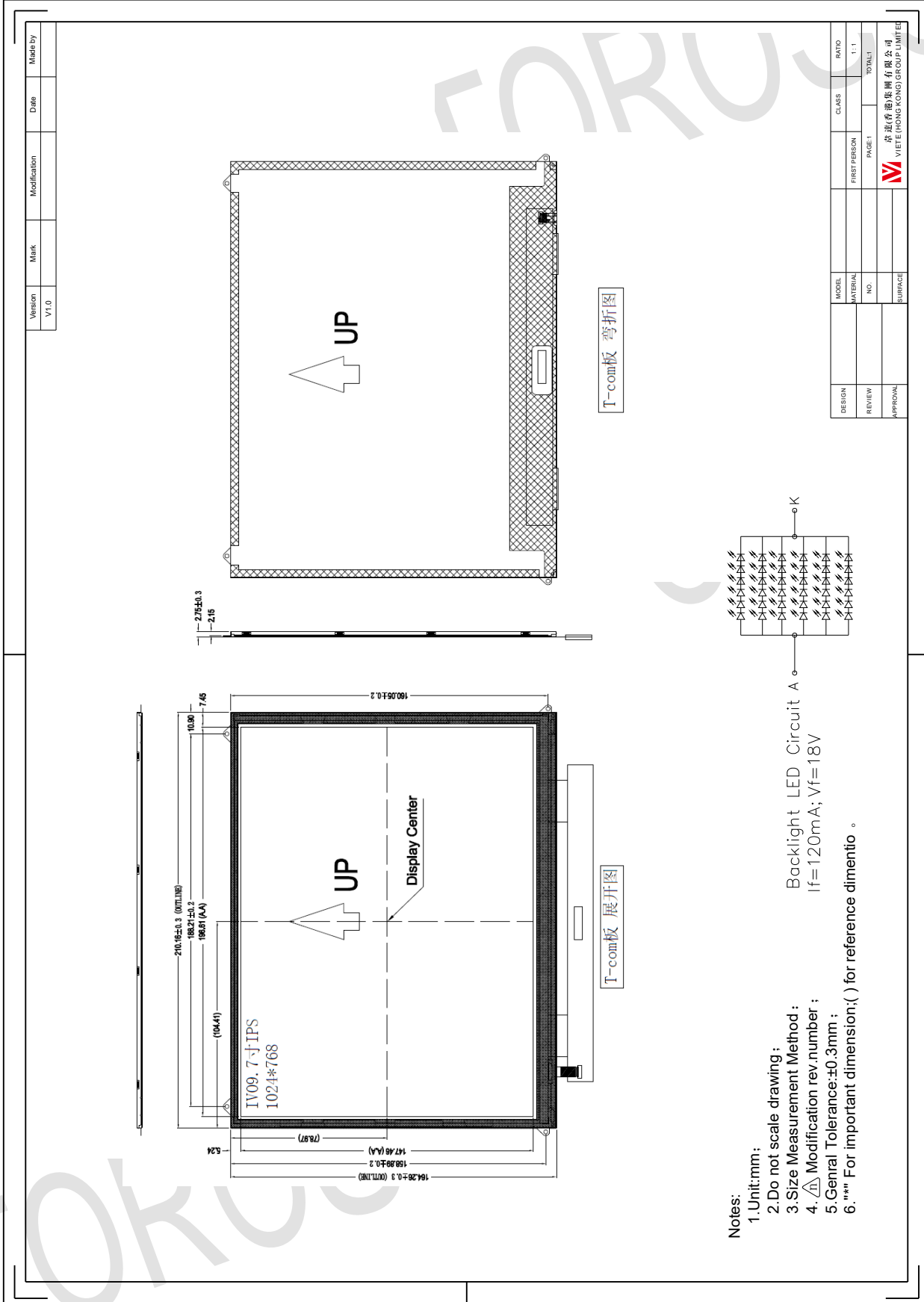

8. Package Drawing

